



MULTILANE SACHET MACHINE MVA500

APPLICATIONS

Vertical form fill and seal of 4 side seal sachets single, twin and shaped

Suitable for medium to low production outputs

Dosing powders, granules, solid, liquid and pasty

TECHNOLOGY

Main drive systems powered by brushless servomotors

Touch screen panel and PLC control

Low maintenance and easy care

MAIN OPTIONS

Laser, Ink jet, Hot foil, and embossing coding for variable data

Transfer groups to the cartoning machines

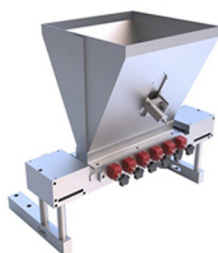

volumetric sliding doser for granulates



filling system for solids

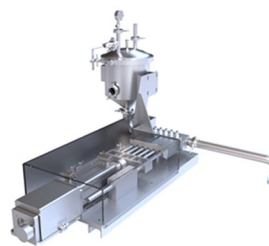

pneumatic rotary valve doser for pasty products

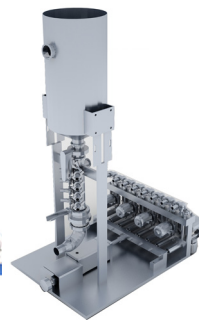

pneumatic membrane valve doser for liquids



auger filling system for powders

SPECIFICATIONS

Innova MVA500 forms, fills and seals 4 side seal flat sachets for liquids, powders, granulates and pasty product, depending on additional accessories. Provided with a 500mm reel diameter, it is designed for medium and low production outputs which require high quality sealing. It is driven by mechanical motion servo and provided with an industrial PC from B&R. It is very flexible in terms of format as it is capable to form a sachet with two different compartments already pre-cutted, different shapes and to change the sachet length through touch screen.

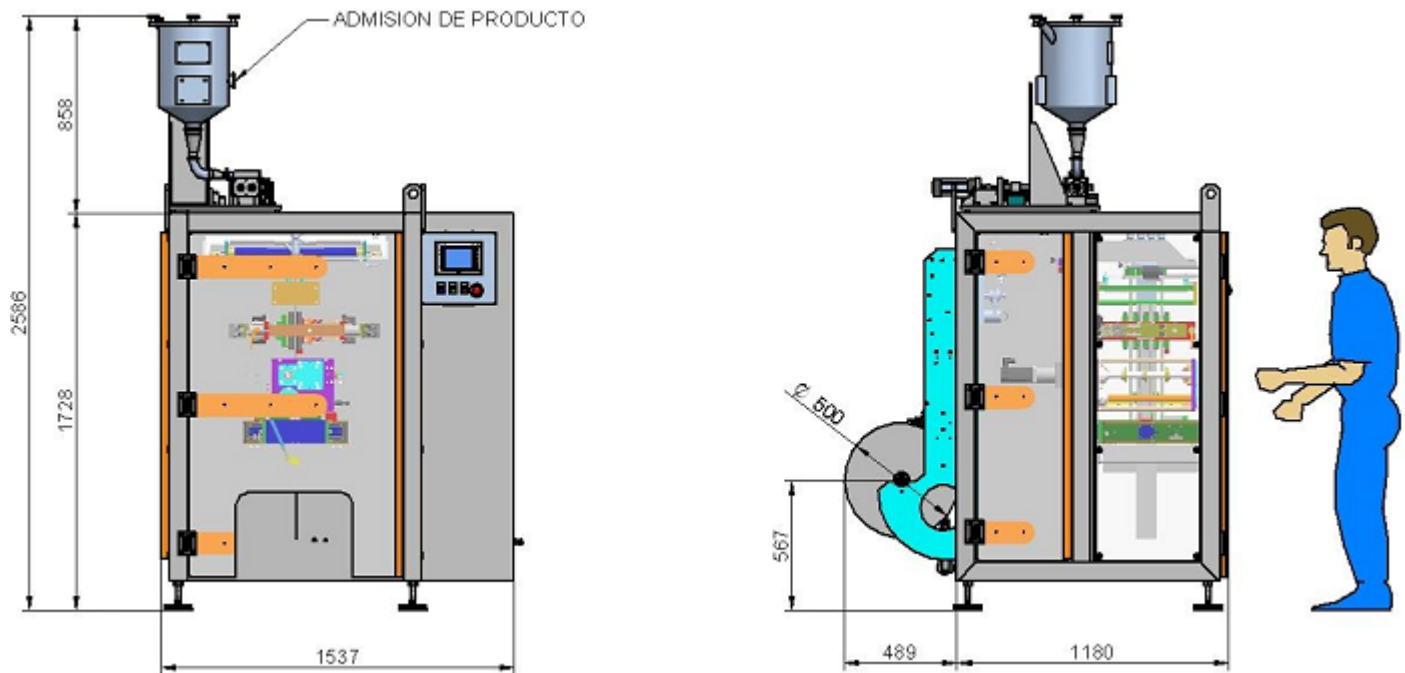

	2 Lanes	3 Lanes	4 Lanes	5 Lanes	5 Lanes	6 Lanes
Max. width (mm)	125	80	60	50	45	40
Min. width (mm)	40					
Max. length (mm)	200					
Min. length (mm)	50					
Max. bobine diametre (mm)	500					
Max. bobine width (mm)	500					
Core (mm)	70/75					
Output (Sachets/minute)	100	150	200	250	250	300
Dimensions (mm)	1.500x1.732x1.728					
Weight (Kg)	1.100					
Noise (dB)	>70					
Electrical data	220, 400, 440, Vac/ 3Ph+N+PE / 50,60Hz 7,5Kwts					
Compressed air	6/7 bar - 1.000 Litres/min.					

Inever, S.L.

Carrer Can Carmany, 3 Pol. Ind. Nord

08310 - Argentona - Barcelona (Spain)

Tel: +34 937 919 611 Fax: +34 937 919 341

www.inever.es